



PROVIDE HIGH-QUALITY ENGINEERING MACHINERY PRODUCTS
AND MAKE THE WORLD FALL IN LOVE WITH MADE IN CHINA

R

WHEEL LOADER

RL06



Hinged design of the machine, with brand power, Soft roar, elegant start, strong and stable output power

RL06 advantages in power, efficiency, versatility and value are driven by our robust features. Our compact articulated design uses less horsepower to do most jobs-that means less surface impact and lower operating costs. Equipped with the Kubota D1105 engine, providing more power support for driving.

RIPPA
MULTIFUNCTIONAL LOADER

RL06



More powerful engine

The power is optimized and matched, with high fuel efficiency, large low-speed torque, strong power and high operating efficiency. An electronically controlled high-pressure common rail fuel system is used to achieve precise combustion control. Intelligently adjust the power curve to meet multiple working modes to achieve high efficiency and fuel saving.

Green and environmentally friendly

In addition to its outstanding horsepower and performance, it also has extremely low noise and vibration levels, excellent fuel efficiency, and meets the final version of Euro V and US Stage IV emission standards, contributing to environmental protection and reducing air pollution.

Compact hinge design

More flexible body, efficient integrated layout, and reduced energy loss during operation.



off-road tires

The core advantage of loader off-road tire is that it can adapt to various complex terrains. Strong grip, reduced idling in slippery environment and guaranteed effective transmission of power; Significantly improve loader trafficability on unpaved pavements for more stable and efficient operation.



radiator

The split-type radiator fits the machine body flexibly, addresses heat dissipation issues specifically, and is easy to maintain and clean.



Maximum unloading height

2060mm





form outstanding lifting capacity to incredible operator comfort, the RL06 has the features to take your performance high

1 INSTRUMENT DISPLAY

The oil level and temperature of the machine can be observed at all times, and the operating status of the machine can be displayed



2 MULTI-FUNCTION JOYSTICK

One-handed operation for moving forward and backward enhances work efficiency and operational precision.



3 CENTRALIZED BUTTON DESIGN

The centralized design of auxiliary buttons greatly improves the convenience of equipment operation.



4 SUSPEHSION SEAT

The seats are also equipped with extendable seat belts to ensure the safety of the driver. The seat allows each operator to find the optimal hip support, backrest tilt angle, and seat position to improve the comfort of the operator.

LINKS AND DRIVES

The lightweight articulated structure and shaft transmission design of the frame, the articulated centering arrangement, strong power, small steering angle and turning radius, better passing ability, and flexible operation



Safety guardrail

The safety guardrail of the loader seat prevents the operator from accidentally falling off in scenarios such as operating on complex terrain, and can cushion impacts and restrict body sway to reduce collision injuries



LED lighting

Night lighting has high brightness and wide range, which can reduce blind spots and improve night operation safety and accuracy; Adapting to harsh environments can extend work time and improve efficiency.

Double top hydraulic cylinder

The dual oil top of the loader can provide stronger and more balanced lifting force, greatly improving stability and efficiency during heavy load operations.



Thickened digging bucket

High quality material selection for digging bucket, sturdy and durable, anti-corrosion and rust proof

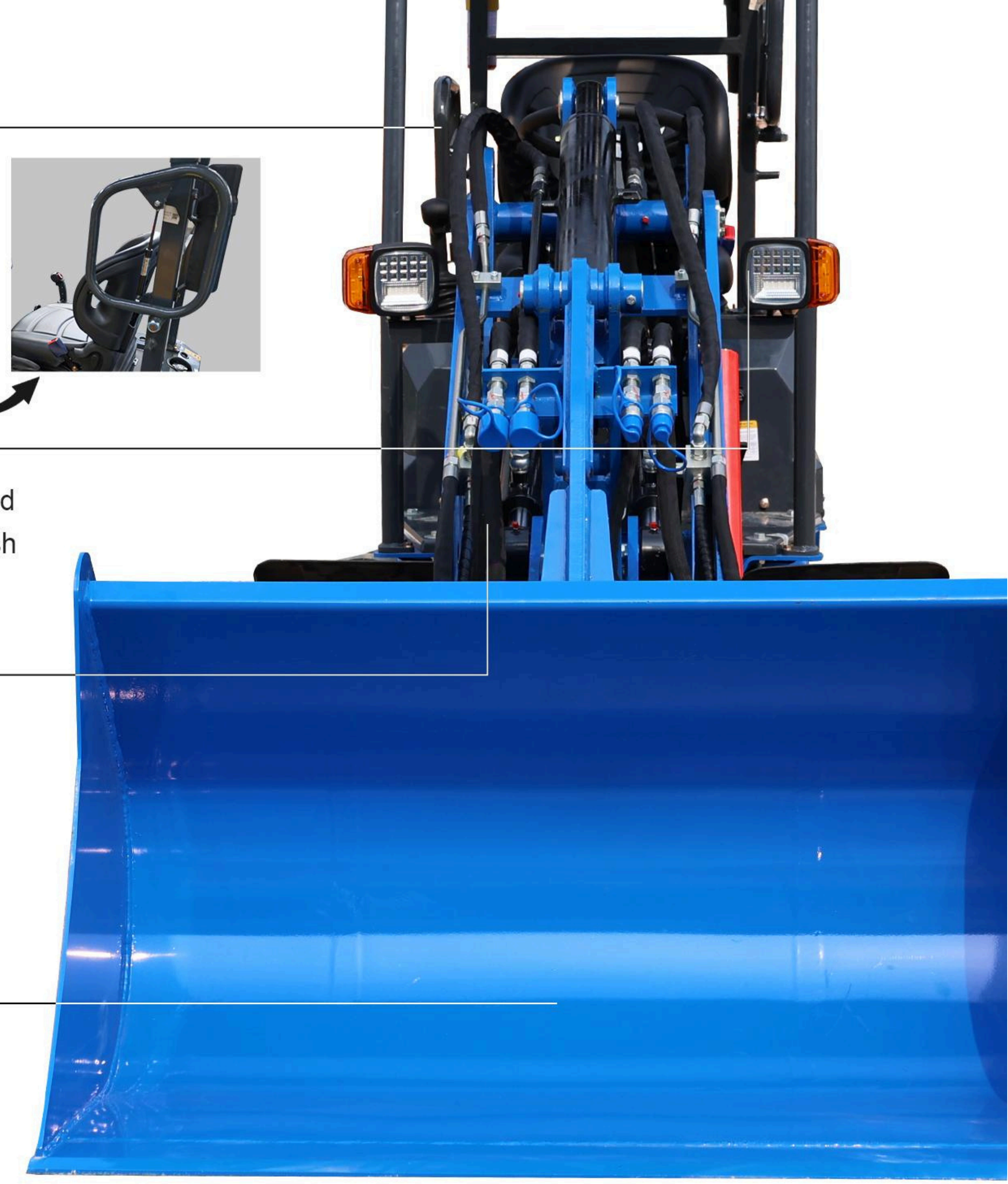

WARNING LIGHT

Capable of alerting surrounding personnel and equipment through flashing lights in complex work environments, adverse weather conditions, and nighttime situations to avoid accidents such as collisions.



If it's easy maintenance you're looking for, take a look at the RL06

Seat for easy access

Opening the loader's seat provides easy access to the engine, filter element, and other components, facilitating quick inspection and maintenance. This design saves time for daily upkeep and troubleshooting.

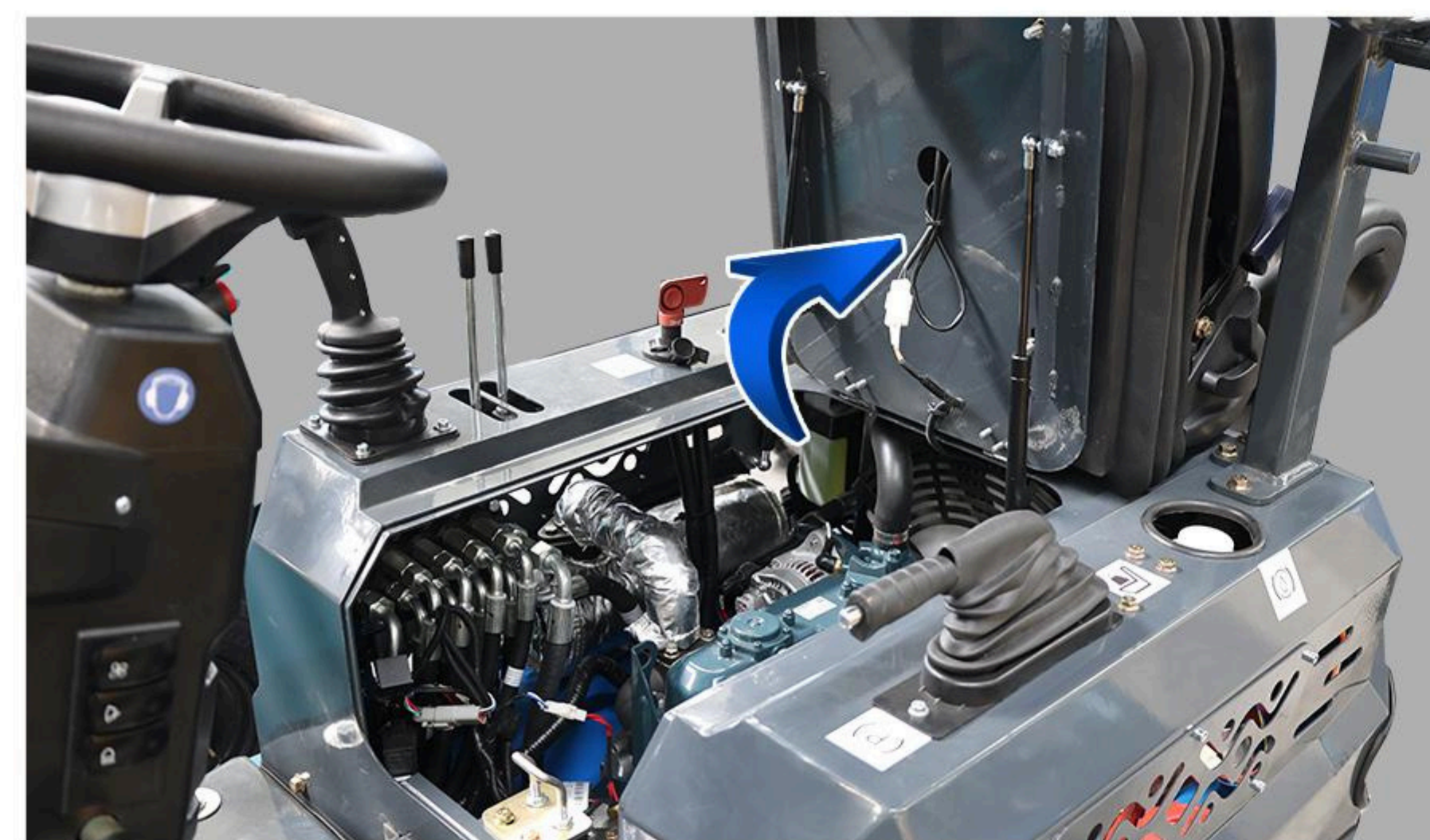

Structured layout

Open the seat, the internal layout is neat, all kinds of pipelines and harnesses are clear, daily inspection of oil, coolant, filter elements, etc. can be quickly reached without complex operation.

Quick change connector

Various auxiliary tools can be easily replaced without complex tools. It also features easy maintainability, and its overall structure facilitates the replacement of vulnerable parts, thus reducing maintenance costs.



filter

The fuel filter and air filter remove impurities to extend the engine's service life. Both ensure the supply of clean fuel and sufficient clean air, facilitating full fuel combustion, maintaining stable engine power output, and enhancing equipment reliability. Meanwhile, they optimize combustion efficiency to improve fuel economy and reduce the engine's maintenance costs.

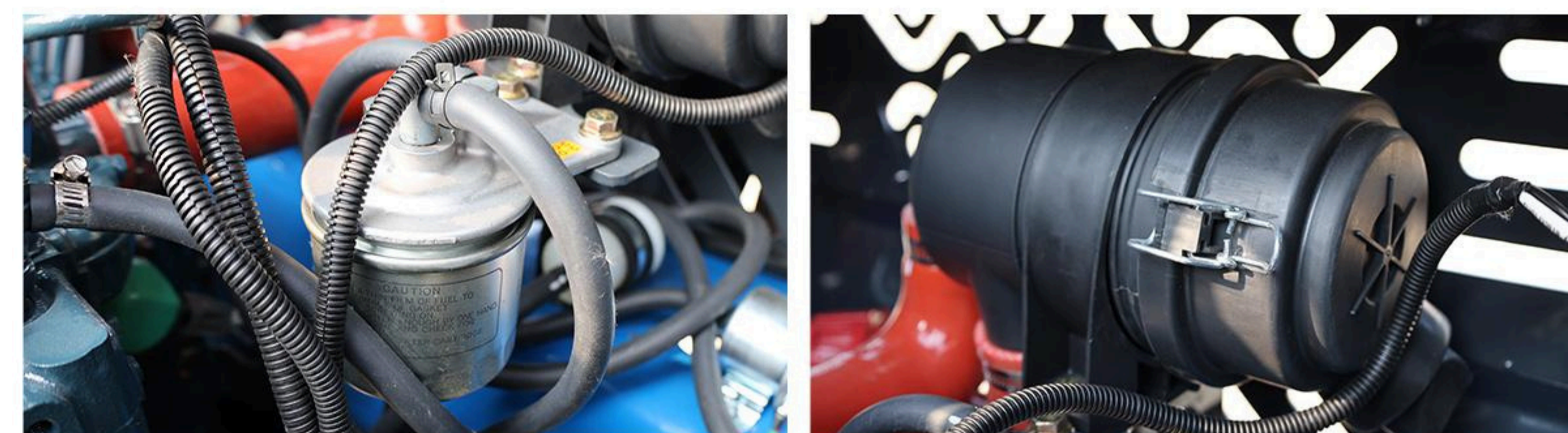

SCOPE OF WORK

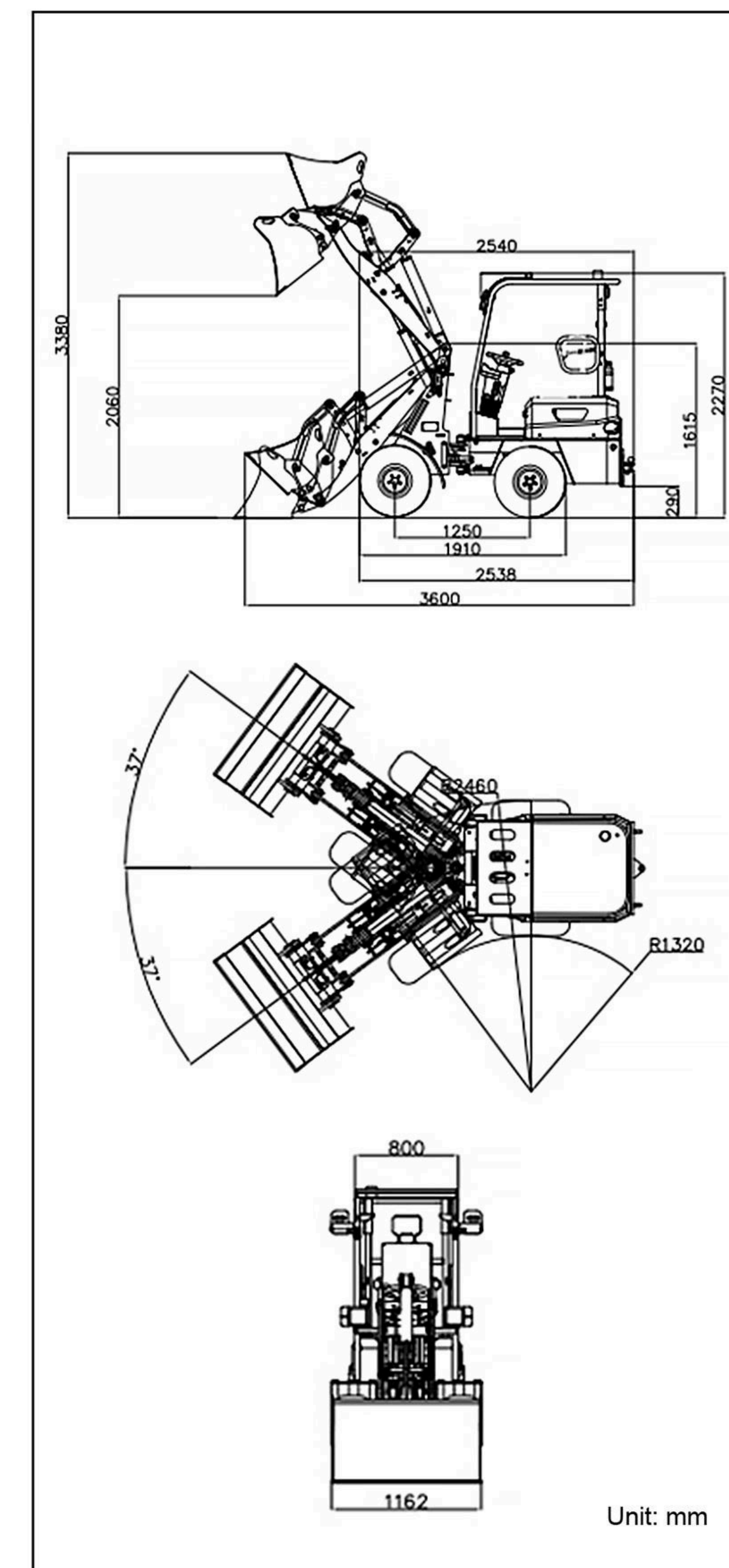

SPECIFICATION

	Model	Unit	RL06
Basic parameters	Machine working weight	lb(kg)	3802 (1725)
	Bucket capacity	ft³(m³)	8.1 (0.23)
	Rated load mass (safe load)	lb(kg)	661 (300)
	Maximum load mass	lb(kg)	1322 (600)
	Walking speed	mph(km/h)	0-5 (0-8)
	Gradability	(%)	25%
	Ground pressure	psi (kpa)	10.6(73.72)
	Maximum unloading height	in(mm)	81.1 (2060)
	Maximum loading height	in(mm)	133.1 (3380)
	Maximum unloading distance	in(mm)	25.6 (650)
Engine	Turning radius	in(mm)	94.5 (2400)
	Wheel base/wheelbase	in(mm)	33/49 (840/1250)
	Minimum ground clearance	in(mm)	6.1 (155)
	Engine brand		Kubota
	Engine model		D1105
	Maximum horsepower	ps(hp)	24.7 (24.4)
	Maximum power	kw	18.2
	Maximum speed	rpm	3000
	Displacement	gal(L)	0.3 (1.123)
	Number of cylinders		3
Body tank	Cooling method		Water-cooled
	Engine oil change amount	gal(L)	1 (4)
	Fuel form		Diesel
	Fuel grade		0/-10
	Theoretical fuel consumption	(L/h)	1.3-1.5
	Transport length - with bucket	in(mm)	143.8 (3650)
	Transport length - without bucket	in(mm)	122.9 (3120)
	Transport width	in(mm)	45.3 (1150)
	Transport height	in(mm)	90.6 (2300)
	Bucket width	in(mm)	45.3 (1150)
Fuel tank	gal(L)	4 (15)	
Hydraulic oil tank	gal(L)	7.4 (28)	

HYDRAULIC SYSTEM

Travel pump type/model	Closed plunger pump V40D32E1M	Multi-way valve	Quadruple multi-way valve
Travel pump brand	Hengli	Working set pressure	20MPa
Travel pump maximum flow rate	96L/min	Walking set pressure	20MPa
Working pump type/model	Gear pump PGP5114GLP	Travel hydraulic motor type	Deston BM5-315
Working pump brand	Tianjin Walking	Travel motor brand	Deston
Working pump maximum flow rate	42L/min	Motor displacement	315

- Please read the instruction manual carefully and use the machine correctly.
- Always wear a seat belt when working. (ROPS specifications only)
- If you are operating construction machinery with a machine mass of less than 3 tons, you must take the "Special Training for Vehicle-Mounted Construction Machinery Operation" course beforehand. If the machine mass is 3 tons or more, you must take the "Vehicle-Mounted Construction Machinery Operation Skills Course".
- To prevent breakdowns and accidents, be sure to inspect the machinery regularly.
- Specific voluntary inspections are required to be carried out by an inspection company registered with the Minister of Health, Labor and Welfare or the Director-General of the Labor Standards Inspection Bureau.

> WE ARE RIPPA

Shandong Rippa Machinery Group Co., Ltd. is located No. 39, Guang'an Road, Liuhan Sub-district Office, High-tech Zone, Jining City, Shandong Province. It is a state-owned high-tech enterprise with import and export rights.

The company's employees are energetic and enterprising, constantly creating the legend and fame of the rippa!



www.rippaofficial.it



WWW.RIPPAOFFICIAL.IT